



DEPARTMENT OF PERMITTING, ENVIRONMENT, AND REGULATORY AFFAIRS (PERA)  
BOARD AND CODE ADMINISTRATION DIVISION

MIAMI-DADE COUNTY  
PRODUCT CONTROL SECTION

11805 SW 26 Street, Room 208  
Miami, Florida 33175-2474  
T (786) 315-2590 F (786) 315-2599

[www.miamidade.gov/pera](http://www.miamidade.gov/pera)

## NOTICE OF ACCEPTANCE (NOA)

**Boral Roofing LLC.**  
7575 Irvine Center Drive, Suite 100  
Irvine, CA. 92618

### SCOPE:

This NOA is being issued under the applicable rules and regulations governing the use of construction materials. The documentation submitted has been reviewed and accepted by Miami-Dade County PERA - Product Control Section to be used in Miami Dade County and other areas where allowed by the Authority Having Jurisdiction (AHJ).

This NOA shall not be valid after the expiration date stated below. The Miami-Dade County Product Control Section (In Miami Dade County) and/or the AHJ (in areas other than Miami Dade County) reserve the right to have this product or material tested for quality assurance purposes. If this product or material fails to perform in the accepted manner, the manufacturer will incur the expense of such testing and the AHJ may immediately revoke, modify, or suspend the use of such product or material within their jurisdiction. PERA reserves the right to revoke this acceptance, if it is determined by Miami-Dade County Product Control Section that this product or material fails to meet the requirements of the applicable building code.

This product is approved as described herein, and has been designed to comply with the Florida Building Code including the High Velocity Hurricane Zone of the Florida Building Code.

### DESCRIPTION: Saxony 600 (Shake, Slate & Split Shake) Concrete Roof Tile

**LABELING:** Each unit shall bear a permanent label with the manufacturer's name or logo, city, state and following statement: "Miami-Dade County Product Control Approved", unless otherwise noted herein.

**RENEWAL** of this NOA shall be considered after a renewal application has been filed and there has been no change in the applicable building code negatively affecting the performance of this product.

**TERMINATION** of this NOA will occur after the expiration date or if there has been a revision or change in the materials, use, and/or manufacture of the product or process. Misuse of this NOA as an endorsement of any product, for sales, advertising or any other purposes shall automatically terminate this NOA. Failure to comply with any section of this NOA shall be cause for termination and removal of NOA.

**ADVERTISEMENT:** The NOA number preceded by the words Miami-Dade County, Florida, and followed by the expiration date may be displayed in advertising literature. If any portion of the NOA is displayed, then it shall be done in its entirety.

**INSPECTION:** A copy of this entire NOA shall be provided to the user by the manufacturer or its distributors and shall be available for inspection at the job site at the request of the Building Official.

This revises NOA# 12-0308.03 and consists of pages 1 through 6.  
The submitted documentation was reviewed by Alex Tigera.



NOA No.: 12-0904.04  
Expiration Date: 12/06/17  
Approval Date: 11/21/12  
Page 1 of 6

## ROOFING ASSEMBLY APPROVAL

**Category:** Roofing  
**Sub-Category:** Roofing Tiles  
**Material:** Concrete

### 1. SCOPE

This approves a system using Saxony 600 (Shake, Slate & Split Shake) Concrete Roof Tile, as manufactured Boral Roofing LLC in Stockton, CA., and described this Notice of Acceptance. For locations where the pressure requirements, as determined by applicable Building Code does not exceed the design pressure values obtained by calculations in compliance with RAS 127 using the values listed in the installation section herein. The attachment calculations shall be done as a moment based system.

### 2. PRODUCT DESCRIPTION

<u>Manufactured by Applicant</u>	<u>Dimensions</u>	<u>Test Specifications</u>	<u>Product Description</u>
Saxony 600 (Shake, Slate & Split Shake)	l = 17" w = 13" .56" thick	TAS 112	Flat, interlocking, high-pressure extruded concrete roof tile equipped with two nail holes. For direct deck or battened nail-on, or adhesive set applications.
Trim Pieces	l = varies w = varies varying thickness	TAS 112	Accessory trim, concrete roof pieces for use at hips, rakes, ridges and valley terminations. Manufactured for each tile profile.

#### 2.1 PRODUCT DESCRIPTION

1. Stockton, CA

#### 2.2 SUBMITTED EVIDENCE:

<u>Test Agency</u>	<u>Test Identifier</u>	<u>Test Name/Report</u>	<u>Date</u>
Redland Technologies	7161-03 Appendix III	Static Uplift Testing PA 102	Dec. 1991
Redland Technologies	7161-03 Appendix III	Static Uplift Testing PA 102(A)	Dec. 1991
The Center for Applied Engineering, Inc.	94-084□	Static Uplift Testing PA 101 (Mortar Set)	May 1994
The Center for Applied Engineering, Inc.	94-060A	Static Uplift Testing PA 101 (Adhesive Set)	March, 1994
The Center for Applied Engineering, Inc.	25-7834-2PA	Static Uplift Testing PA 101 (Horizontal Battens w/ 2 screws)	Oct. 1996
The Center for Applied Engineering, Inc.	25-7834-4PA	Static Uplift Testing PA 101 (Horizontal Battens w/ 2 screws)	Oct. 1996
The Center for Applied Engineering, Inc.	257814-4PA	Static Uplift Testing PA 101 (2 Screws)	Sept. 1996



**NOA No.:** 12-0904.04  
**Expiration Date:** 12/06/17  
**Approval Date:** 11/21/12  
 Page 2 of 6

## 2.2 SUBMITTED EVIDENCE:

<u>Test Agency</u>	<u>Test Identifier</u>	<u>Test Name/Report</u>	<u>Date</u>
The Center for Applied Engineering, Inc.	25-7094-2	Static Uplift Testing PA 102 (4" Headlap, Nails, Direct Deck, New Construction)	Oct. 1994
The Center for Applied Engineering, Inc.	25-7094-8	Static Uplift Testing PA 102 (4" Headlap, Nails, Battens)	Oct. 1994
The Center for Applied Engineering, Inc.	25-7094-5	Static Uplift Testing PA 102 (4" Headlap, Nails, Direct Deck, Recover/Reroof)	Oct. 1994
The Center for Applied Engineering, Inc.	25-7183-6	Static Uplift Testing PA 102 (2 Quik-Drive Screws, Direct Deck)	Feb. 1995
The Center for Applied Engineering, Inc.	25-7183-5	Static Uplift Testing PA 102 (2 Quik-Drive Screws, Battens)	Feb. 1995
The Center for Applied Engineering, Inc.	25-7214-1	Static Uplift Testing PA 102 (1 Quik-Drive Screw, Direct Deck)	March, 1995
The Center for Applied Engineering, Inc.	25-7214-5	Static Uplift Testing PA 102 (1 Quik-Drive Screw, Batten)	March, 1995
Redland Technologies	7161-03 Appendix II	Wind Tunnel Testing PA 108 (Nail-On)	Dec. 1991
Redland Technologies	Letter Dated Aug. 1, 1994	Wind Tunnel Testing PA 108 (Nail-On)	Aug. 1994
Redland Technologies	P0631-01	Wind Tunnel Testing PA 108 (Mortar S)	July 1994
Redland Technologies	P0402	Withdrawal Resistance Testing of screw vs. smooth shank nails	Sept. 1993
The Center for Applied Engineering, Inc.	Project No. 307025	Wind Driven Rain	Oct. 1994
Walker Engineering, Inc.	Test #MDC	PA 100	Sept. 2007
Nutting Engineers	Evaluation Calculations 13343.1	Restoring Moments Due to Gravity TAS 112	January 2007

## 3. LIMITATIONS

- 3.1 Fire classification is not part of this acceptance.
- 3.2 For mortar or adhesive set tile applications, a static field uplift test shall be performed in accordance with TAS 106.
- 3.3 Applicant shall retain the services of a Miami-Dade County Certified Laboratory to perform quarterly test in accordance with TAS 112, appendix 'A'. Such testing shall be submitted to the Building Code Compliance Office for review.
- 3.4 Minimum underlayment shall be in compliance with the applicable Roofing Applications Standards listed section 4.1 herein.
- 3.5 30/90 hot mopped underlayment applications may be installed perpendicular to the roof slope unless stated otherwise by the underlayment material manufacturers published literature.
- 3.6 This acceptance is for wood deck applications. Minimum deck requirements shall be in compliance with applicable building code.



#### 4. INSTALLATION

- 4.1 Saxony 600 (Slate, Shake & Split Shake) Concrete Roof Tile and its components shall be installed in strict compliance with Roofing Application Standard RAS 118, RAS 119, and RAS 120.
- 4.2 Data For Attachment Calculations

Table 1: Average Weight (W) and Dimensions (l x w)			
Tile Profile	Weight-W (lbf)	Length-l (ft)	Width-w (ft)
Saxony 600 Slate, Shake & Split Shake	6.85	1.417	1.08

Table 2: Aerodynamic Multipliers - $\lambda$ (ft <sup>3</sup> )		
Tile Profile	$\lambda$ (ft <sup>3</sup> ) Batten Application	$\lambda$ (ft <sup>3</sup> ) Direct Deck Application
Saxony 600 Slate, Shake & Split Shake	0.289	0.313

Table 3: Restoring Moments due to Gravity - $M_g$ (ft-lbf)												
Tile Profile	2":12"		3":12"		4":12"		5":12"		6":12"		7":12" or greater	
	Battens	Direct Deck	Battens	Direct Deck	Battens	Direct Deck	Battens	Direct Deck	Battens	Direct Deck	Battens	Direct Deck
Saxony 600 Slate, Shake & Split Shake	4.22	4.80	4.18	4.75	4.11	4.67	4.03	4.58	3.92	4.46	3.81	4.33

Table 4: Attachment Resistance Expressed as a Moment - $M_r$ (ft-lbf) for Nail-On Systems		
Tile Profile	Tile Application	Approved Screws
		2 screws
Saxony 600 Slate, Shake & Split Shake	Battens	17.4
	Direct Deck	28.70

1 Data noted in Table 3 is for installation with a 3" tile headlap.

Table 7: Attachment Resistance Expressed as a Moment - $M_r$ (ft-lbf) for Mortar or Adhesive Set Systems		
Tile Profile	Tile Application	Attachment Resistance
Saxony 600 Slate, Shake & Split Shake	Adhesive Set <sup>1</sup>	75.8 <sup>2</sup>

1. 3M™ 2-Component Foam Roof Tile Adhesive AH-160  
2. Average patty weight was 45.6 grams



## 5. LABELING

All tiles shall bear the imprint or identifiable marking of the manufacturer's name or logo (See **Detail Below**), or following statement: "Miami-Dade County Product Control Approved".

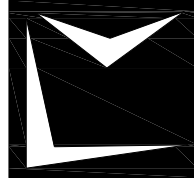

**BORAL ROOFING LLC SAXONY 600 TILE (STOCKTON, CA PLANT)  
(LOCATED ON UNDERSIDE OF TILE)**

## 6. BUILDING PERMIT REQUIREMENTS

**6.1** Application for building permit shall be accompanied by copies of the following:

**6.1.1** This Notice of Acceptance.

**6.1.2** Any other documents required by the Building Official or applicable building code in order to properly evaluate the installation of this system.

## PROFILE DRAWINGS

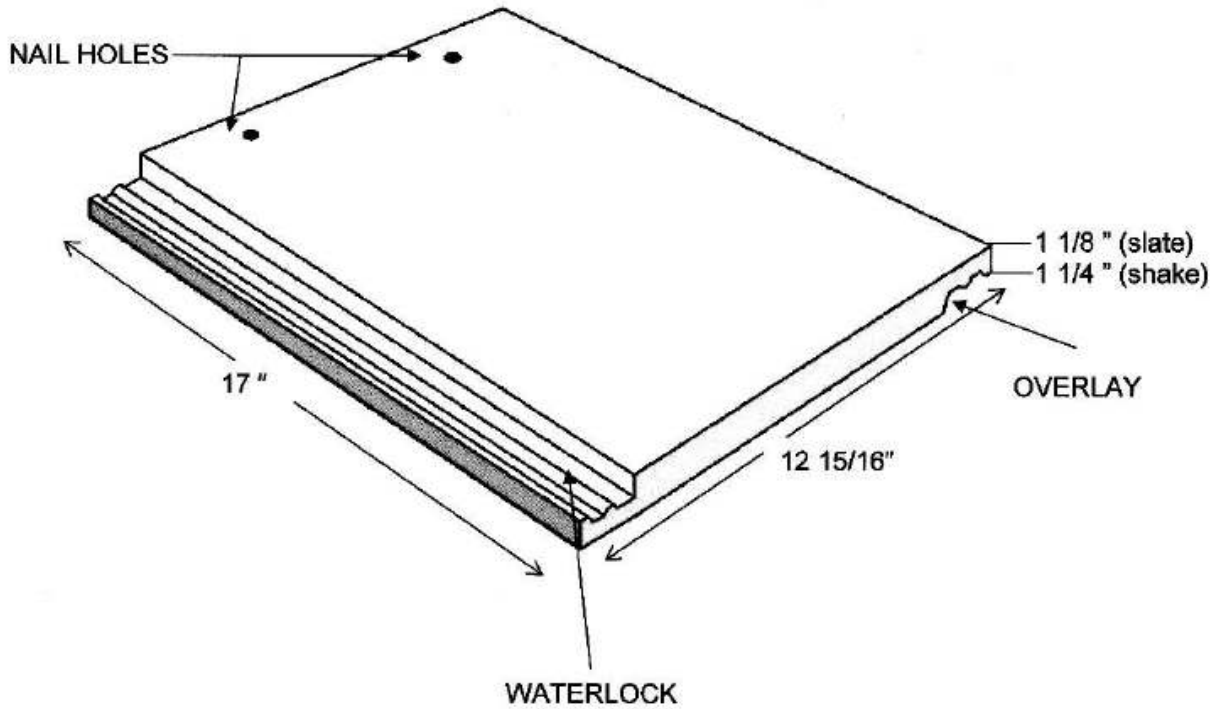

**SAXONY 700 CONCRETE ROOF TILE (STOCKTON, CA)**

**END OF THIS ACCEPTANCE**